

Cylindrical flow regulators with core hole – chamber diameter effect

Cylindryczne regulatory przepływu z otworem ślepy – efekt średnicy komory

MAREK OCHOWIAK, SYLWIA WŁODARCZAK, IVAN PAVLENKO, ANDŻELIKA KRUPIŃSKA, MAŁGORZATA MARKOWSKA, LESZEK DUDEK, CEZARY PIECKA

DOI 10.36119/15.2020.10.8

The standard and modified liquid flow regulators were tested in this work. In modified regulators a cylindrical core hole was installed in the regulator axis. It takes the shape of a cylinder, without a base being tangent to the wall of the regulator. It is placed on the wall opposite to the outlet. The „core-hole” effect in the outflow of water from the tank contributes to the stabilization of the outflow, however, for the tested devices, a slight increase in the discharge coefficient was observed, which is undesirable in this case. It should be noted that this increase is small and should not be assessed unequivocally negatively, because stabilization of the core and even outflow of liquid are also important. It has been shown that the value of the discharge coefficient decreases with increasing diameter of the swirl chamber. The research with the participation of cylindrical vortex regulators containing a core hole, which is the subject of this article, is to be an extension of the existing knowledge on this phenomenon.

Keywords: Modified flow regulators; discharge coefficient; liquid flow; cylindrical regulator.

W pracy przebadano standardowe i zmodyfikowane regulatory przepływu cieczy. W regulatorach zmodyfikowanych w osi rozpylacza zainstalowano cylindryczny otwór ślepy (ang. core-hole). Przyjmuje on kształt walca, pozbawionego podstawy, będącej styczną ze ścianą regulatora. Umieszcza się go na ścianie przeciwległej do otworu wylotowego. Efekt „core-hole” w odpływie wody ze zbiornika przyczynia się do ustabilizowania wypływu, jednak dla badanych urządzeń zaobserwowano nieznaczny wzrost współczynnika wypływu, co jest w tym przypadku niepożądane. Należy zaznaczyć, że wzrost ten jest niewielki i nie należy go oceniać jednoznacznie negatywnie, gdyż ustabilizowanie rdzenia i równomierny wypływ cieczy są również istotne. Wykazano, że wartość współczynnika wypływu maleje ze wzrostem średnicy komory wirowej. Badania z udziałem wirowych regulatorów cylindrycznych zawierających otwór ślepy, które są tematem tej pracy, mogą być rozszerzeniem dotychczasowej wiedzy dotyczącej tego zjawiska. *Słowa kluczowe: zmodyfikowane regulatory przepływu; współczynnik wypływu; przepływ cieczy; regulator cylindryczny.*

Introduction

The scale of installations in the chemical and related industries is very wide, from multi-meter devices to millimetre detectors. Regardless of whether we are dealing with a multi-kilometre pipeline or a millimetre diameter hose that is part of an advanced micro reactor, flow control in this system is essential. The use of accurate throttling devices ensures that the dosed volume meets the predetermined parameters, and the process will run with a certain determined efficiency. The problem of throttling the flow has already been considered many times, and the solutions developed over the years are successfully used

to this day. Devices such as valves and orifices have become a permanent feature of everyday use, yet their structure and mode of operation are not generally known. This widespread use, however, does not exempt from attempts to search for and research new, improved versions. The new solutions are not only to be reliable and resistant to long-term operation, they are also to be easy and cheap to produce, their range of applications is to be as wide as possible and the degree of throttling, depending on the situation, should be adjusted so that the number of elements is as limited as possible. A solution to these problems could be a check valve invented by Thom. Its subsequent

modifications and changes in geometry are the subject of intensive research, because the main disadvantage of this type of solutions is the lack of general assumptions that could describe all or a specific group of regulators. The multitude of variables influencing the main parameters of the outflow in this type of apparatus prevents its meaningful mathematical description. Currently conducted research is aimed at determining the interrelationships between two or three parameters (e.g. diameter of inlet pipe and diameter and height of cone). These problems are the driving force for subsequent tests, because with the current state of knowledge, determining the performance characteristics of

dr hab. inż. Marek Ochowiak prof. PP <https://orcid.org/0000-0003-1543-9967>, dr inż. Sylwia Włodarczak <https://orcid.org/0000-0003-0561-0177>, Ph.D., Associate Professor, Ing. Ivan Pavlenko <https://orcid.org/0000-0002-6136-1040>, mgr. inż. Anżelika Krupińska <https://orcid.org/0000-0002-1485-9794>, mgr. inż. Małgorzata Markowska <https://orcid.org/0000-0001-6219-9666>, inż. Leszek Dudek, inż. Cezary Piecka – Department of Chemical Technology and Engineering, Poznan University of Technology, Poznan, Poland. Corresponding author: marek.ochowiak@put.poznan.pl
Ivan Pavlenko – Department of General Mechanics and Machine Dynamics, Sumy State University, Sumy, Ukraine

each individual limiter consists in performing a series of experiments with its use. It is a time-consuming and ineffective system, and the only way to improve this state is to build new models and work on showing relations between variables.

A flow regulator is a device designed to give a constant flow regardless of the liquid level at the outlet. These devices are used in networks to regulate the flow of rainwater. They are mostly used in structures such as: storm chambers, storm overflows, rainwater retention reservoirs, rainwater sewage systems, water purification devices [1]. In traditional flow regulating devices such as orifices, dampers or gate valves, a relatively simple adjustment of the flow rate can be achieved by changing the cross section of the pipe on which they are mounted. This solution can cause blockage of the flow in particular when the flowing liquid is contaminated. In addition, the fact that it has moving parts in its construction, including these devices among active regulators, results in reducing the reliability of such devices and the possibility of mechanical failures. Passive regulators that do not have moving parts do not have these disadvantages [2]. In passive devices, the flow is limited by using linear or local resistances. The first model of a vortex flow control device, a so-called check valve, was patented by Thoma in 1921 [3, 4]. It was also called a vortex diode because its principle of operation resembled that of a diode, namely, it allowed the fluid to flow freely in one direction and limited it in the opposite direction. When water is fed to this diode only from the throttle side, it can be called a throttle, vortex valve or flow regulator [4, 5]. The device has become and still is the subject of many studies aimed at the best optimization in terms of:

- high hydraulic efficiency,
- geometric parameters.

Works have also been carried out on a detailed mathematical description for the design of check valves. This is complicated because vortex flow restriction binds many variables together. Currently, experimental studies are used to fine-tune the ranges of applicability of a given regulator. There are many types of throttles on the market, they differ in structure, properties and mounting methods. Taking into account the application of the vortex effect, they can be divided into [6]:

- cylindrical vortex regulator,
- conical hydrodynamic regulator.

There are also non-vortex regulators:

- trough regulator,
- Venturi regulator,
- float regulators.

Vortex valves have a low failure rate due to the lack of moving parts, larger inlet and outlet openings and the possibility of self-cleaning, where the contaminants remaining in the regulator after heavy rains are washed away due to the creation of a new vortex flow. Non-vortex valves also have a relatively low failure rate, because, similarly to vortex regulators, they do not have mechanical elements or they are so simple in construction that they are difficult to block [5, 7, 8]. This article presents results of the study carried out for classical vortex flow regulators and new "core-hole" modified regulators.

Case study

In order to stabilize the outgoing stream, the work [9] makes an attempt to modify the system in order to optimize and increase the stability of the outgoing stream. For this purpose, a cylindrical core hole was installed in the atomizer axis. It takes the shape of a cylinder, without a base being tangent to the wall of the regulator. It is placed on the wall opposite to the outlet [9, 10]. The core hole is a natural extension of the air core being formed (Fig. 1).

Fig. 1. Cylindrical vortex regulators [11]: a) classical construction with symbols, b) with a core-hole

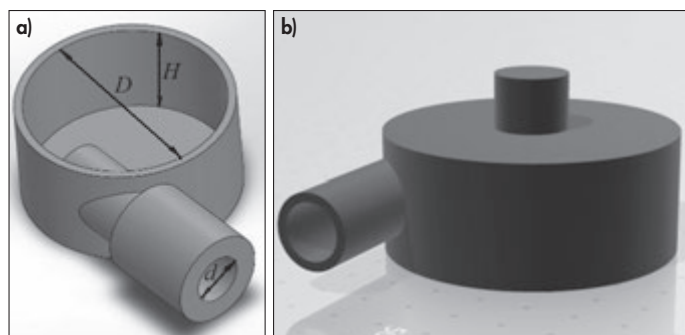

It has been proven that the use of this element allows to obtain a stream with a regular outline, additionally it is characterized by a lower value of the thickness and also smaller fluctuations. The use of a core hole therefore appears to be a promising opportunity to improve the spraying aspect in areas such as flow control or atomization. The research with the participation of cylindrical vortex regulators containing a core hole, which is the subject of this article, is to be an extension of the existing knowledge on this phenomenon, and additionally another element facilitating the mathematical description of the relations formed in this case.

The number of test results available in the literature on vortex flow regulators used to throttle the liquid flow is still insignificant, and their description of operation is practically reduced to the Toricelli formula:

$$\mu = \frac{Q}{A\sqrt{2g\Delta H}} \quad (1)$$

where: Q is the volumetric flow rate of the liquid, A – the cross-sectional area of the inlet pipe, g – gravitational acceleration, ΔH – liquid accumulation.

This paper presents selected results of experimental tests of the discharge coefficient for flow regulators with a modified design. The first point in the practical part of the work was the appropriate selection of dimensions in such a way that the spectrum of the conducted research was as wide as possible. Taking into account the results of previous studies [12, 13], the values had to be selected so as to include the best described variants of the regulators. It was decided that the tests would be conducted on a cylindrical vortex regulator, designed and manufactured in two variants. The first of these is a cylindrical regulator with three sizes of the inner diameter of the chamber D . According to the relations described in the works [12, 14], the value of the inner diameter of the chamber to the diameter of the inlet was set at the level of: $D = 3d$, $D = 4d$ and $D = 5d$

(described as: 3d, 4d and 5d with/without core hole), respectively, which assuming that the inlet diameter is equal to the outlet diameter $d = 12$ mm, results in three sizes of regulators with diameters $D = 36$, 48 and 60 mm. As shown in the theoretical part of this work, the equal diameter of the inlet and outlet openings allows to achieve the value of the discharge coefficient at the lowest possible level which is most desirable. Also, the ratio of the chamber diameter to the hole diameter D/d is within the range with a low coefficient in relation to the relative radius of vortices. Then, the height of the swirl chamber was selected, which in all tested specimens was $H = 26$ mm. This gives the value of the ratio $H/d = 2.17$, which is within the limits for which the regulator achieves stable values of the μ coefficient. The device described in this work consists of two elements: a swirl

chamber with an inlet port, which was built tangentially to the one creating a regulator, and a lid put on the chamber with an outlet. The thickness of the lid walls as well as the chamber walls is 2 mm. The lid is connected to the chamber by means of a waterproof silicone. The second tested variant is a modification of the first regulator, additionally equipped with a core hole. The core hole is an element of the regulator located in its symmetry axis on the wall opposite to the outlet. It takes the shape of a cylinder, without a base being tangent to the wall of the regulator. It is a natural extension for the emerging air core. The diameter and height of the hole are equal to 12 mm. Knowing all the geometric dimensions, it was possible to prepare technical documentation containing the object in three projections and isometric visualization for each of the chambers in the version without a core hole and with a core hole, as well as separate drawings showing the lid in three diameter variants. The drawings were made in the AutoCAD graphics program by Autodesk (Fig. 2) [11].

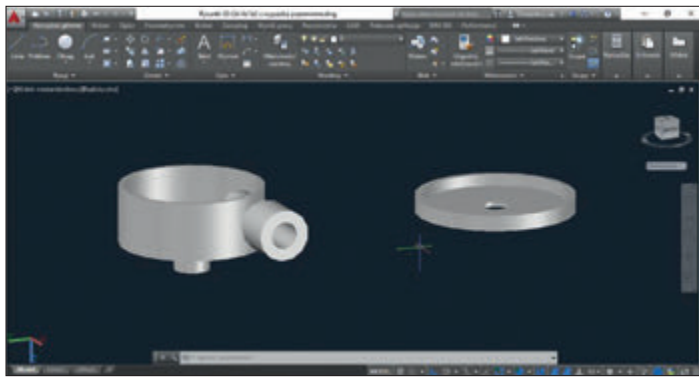

Fig. 2. A model of a cylindrical regulator with a core hole made in AutoCAD program [11]

A number of flow regulators with different shapes of the swirl chamber and regulators with a "core hole" were designed, printed and then tested. The prepared projects were implemented based on the system of rapid production of models, the so-called 3D printout. The Fused Deposition Modelling technology used in this process consists in the gradu-

al application of successive layers of molten polymer in such a way as to create the desired object. The obtained printouts very accurately reflect the spatial computer model. The material used to produce the regulators is reinforced acrylonitrile-butadiene-styrene copolymer ABS, which makes the products resistant to high temperature and mechanical damage.

The elements included in the test stand (Fig. 3) for analysing the cylindrical flow regulator are:

- valve transmitting tap water,
- rubber hose for transporting fluid from the sewage system to the tank,
- cylindrical tank with dimensions $H_T = 2000$ mm, $D_T = 100$ mm with a 100 mm graduation made of acrylic glass (poly (methyl methacrylate),
- measuring vessel,
- WPT60C2 electric platform scales by Radwag with an accuracy of 0.002 kg,
- MAGMA 10 stopwatch with an accuracy of 0.01 s,
- thermocouple thermometer.

Analysis of the results

The dependence of the discharge coefficient on the Reynolds number and Froude number was analysed, defined by the equations respectively:

$$Re = \frac{wd\rho}{\eta} \quad (2)$$

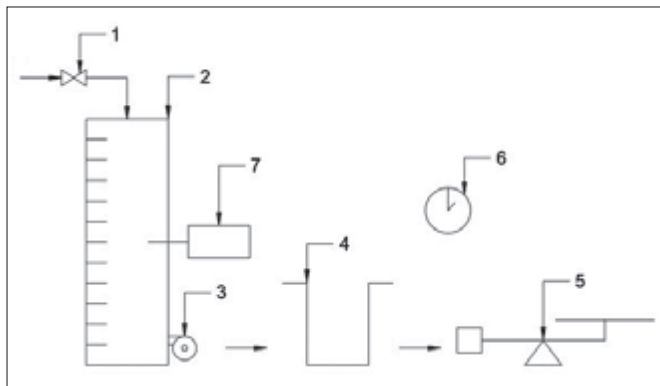

Fig. 3. Diagram of test stand 1 – valve, 2 – tank, 3 – cylindrical flow regulator, 4 – measuring vessel, 5 – scales, 6 – stopwatch, 7 – thermometer

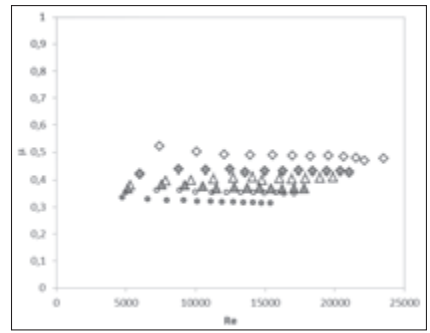

Fig. 4. A comprehensive chart of the dependence of the value of the discharge coefficient μ on the Reynolds number for a cylindrical flow regulator. (\diamond 3d with core hole; \bullet 3d without core hole; \triangle 4d with core hole; \cdot 4d without core hole; \square 5d with core hole; \square 5d without core hole)

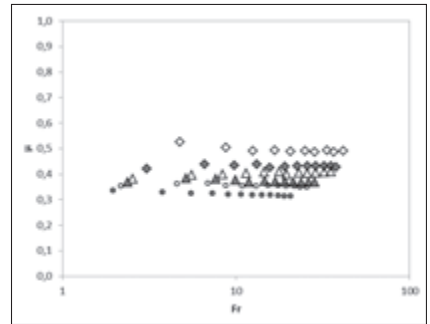

Fig. 5. A comprehensive chart of the dependence of the value of the discharge coefficient μ on the Froude number for a cylindrical flow regulator. (\diamond 3d with core hole; \bullet 3d without core hole; \triangle 4d with core hole; \cdot 4d without core hole; \square 5d with core hole; \square 5d without core hole)

$$Fr = \frac{Q}{2g\pi^2(d/2)^5} \quad (3)$$

Thanks to the use of such a procedure, it is possible to visualize the changes in the discharge coefficient in relation to the Reynolds number and Froude number (Fig. 4 and 5) and their preliminary construction analysis as to the application.

The collected data can be considered in two separate approaches. The first is the analysis of regulators in terms of their throttling properties. Considering the presented problem in this way, it is necessary to take into account what is the average value of the discharge coefficient assigned to a given regulator. The relevant data are summarized in Table 1.

Table 1. Values of the discharge coefficient.

Chamber diameter D [mm]	Discharge coefficient m [-] for regulators with a core hole	Discharge coefficient m [-] for regulators without a core hole	Difference in [%]
36	0.49	0.43	8.7
48	0.40	0.37	9.2
60	0.36	0.32	8.9

In the case of throttling, the coefficient μ of lower value defines the regulators which perform better. This coefficient determines the ratio of the flow rate calculated on the basis of the mass of water flowing out at a given time to the flow rate that can theoretically be obtained for a given cross-sectional area of the inlet and a given height of the liquid column. This means that the lower the coefficient value, the more limited the flow. It was observed that for the regulator with a chamber diameter of 60 mm, the value was 0.32, which is the lowest recorded result. It follows that in this case the selection of geometrical parameters and the absence of a core hole resulted in the occurrence of a significant hydraulic resistance. In opposition there is a regulator with a chamber diameter of 36 mm containing a modification in the form of a core hole, for which the calculated coefficient has the value of 0.49. The presence of a core hole is responsible for this result. In all tested cases the regulators with this element are characterized by a higher value of μ , for example, a regulator with a swirl chamber diameter of 36 mm with a standard design without a core hole has an discharge coefficient of 0.43, while when it is equipped with a blind hole 0.49.

This dependence confirms the hypothesis about the "core-hole" effect in cylindrical swirl regulators. All values were within the range given by both the researchers of the phenomenon and manufacturers of this type of devices. The "core-hole" effect in the outflow of water from the tank contributes to the stabilization of the outflow, however, for the tested devices, a slight increase in the discharge coefficient was observed, which is undesirable in this case. It should be noted that this increase is small and should not be assessed unequivocally negatively, because stabilization of the core and even outflow of liquid are also important. Stabilization of the outflow may be important in precise control of the liquid stream, i.e. without large fluctuations in the values of the volumetric intensity of the liquid flowing in a given system.

By analysing the curves of the dependence of the coefficient on the criterion numbers, it was registered that in the tested range of the height of the liquid column, the regulators operated in the swirl mode. As a result, the charts are devoid of significant deviations from the mean, which confirms the results of the research [15,

16]. The analysis of the obtained results showed that the use of an additional element in the form of a cylindrical core hole has a positive effect on the atomizing aspect. A regular stream with a constant thickness of the liquid film forms on the drainage ring [11]. The observed film forms around the entire circumference of the outlet, which distinguishes these regulators from the others.

The obtained results are not only of cognitive but also practical significance, as the tested designs of the flow regulators are characterized by a relatively simple structure that does not require moving parts, so it seems advisable to continue their research.

Conclusions

This paper presents selected results of laboratory model study concerning the influence of the flow regulator construction on the discharge coefficient.

On the basis of analysis of the results has been shown that:

- the "core-hole" effect contributes to the stabilization of the liquid outflow,
- in the cases of modified regulators a slight increase in the discharge coefficient was observed,
- the value of the discharge coefficient decreases with increasing diameter of the swirl chamber of the regulator.

The obtained results are very important from the practical point of view because the cylindrical flow regulators are used for diversion and/or limiting excess discharge in wastewater and stormwater systems as a replacement for traditional flow throttling devices. They are highly efficient, reliable and free from common disadvantages of traditional devices. Additionally, the "core-hole" stabilizes the thickness of the liquid film.

NOMENCLATURE

A	- Cross-sectional area of the inlet pipe	m^2
d	- Outlet/inlet pipe diameter	m
D	- Chamber diameter	m
D_T	- Tank diameter	m
Fr	- Froude number	-
H	- Chamber height	m
H_T	- Tank height	m
Re	- Reynolds number	-
w	- Liquid velocity	m/s
Q	- Volumetric flow rate of the liquid	m^3/s

g	- Gravitational acceleration	m/s^2
DH	- Liquid accumulation	m

Greek symbols

η	- Viscosity	$Pa \cdot s$
m	- Discharge coefficient	-
ρ	- Density	kg/m^3

ACKNOWLEDGMENT

This work was supported by the Polish Ministry of Science and Higher Education (PUT 0912/SBAD/0902).

REFERENCES

- [1] biocent.com.pl/regulatory-przeplywu z dnia 12.05.2019.
- [2] A. Kotowski, Podstawy bezpiecznego wymiarowania odwodnień terenów, Wydawnictwo Seidel-Przywecki Sp. z o.o., Warszawa 2011.
- [3] Thoma D., Die Ruckstormdrossel. VDI-Zeitschrift, 74 (1930) 1098, na podstawie [4].
- [4] Wójtowicz P., Kotowski A., Badania modelowe cylindrycznych regulatorów hydrodynamicznych. Ochrona Środowiska 30(2) (2008) 35-41.
- [5] M. Ochowiak, S. Woźniowski, M. Matuszak, S. Włodarczyk, Automatyka i miernictwo przemysłowe. Laboratorium, Bel Studio, Warszawa 2018.
- [6] oksydan.pl/produkty/armatura-kanalizacyjna-2/regulatory-przeplywu z dnia 10.01.2020.
- [7] www.vandbremse.dk z dnia 10.01.2020
- [8] www.puraqua.pl/wirowy-regulator-przeplywu-pur-reg-1/ z dnia 10.01.2020
- [9] S. Kim, T. Khil, D. Kim., T. Yoon, Effect of geometric parameters on the liquid film thickness and air core formation in a swirl injector, Measurements Science Technology 21(3) (2009) 1-11.
- [10] S. Kim, D. Kim, T. Khil, Y. Yoon, Effect of geometry on the liquid film thickness and formation of air core in a swirl injector, The 43rd AIAA/ASME/SAE/ASEE Joint Propulsion Conference & Exhibit 2007, AIAA-2007-5460, s. 1-8, Cincinnati 2007.
- [11] C. Piecka, L. Dudek, Efekt „core-hole” w odpływie wody ze zbiornika, Praca Inżynierska, Wydział Technologii Chemicznej, Politechnika Poznańska, Poznań 2020.
- [12] J. Warych Aparatura chemiczna i procesowa, Oficyna Wydawnicza Politechniki Warszawskiej, Warszawa 2004.
- [13] termen.pl/oferta/zawory-regulatory/zawory-bezpieczenstwa-zbm z dnia 20.12.2019.
- [14] www.rynekinstalacyjny.pl/arttykul/id3380,zawory-zasuwowe-przeglad-konstrukcji z dnia 03.01.2020.
- [15] P. Wójtowicz, A. Kotowski, Badania modelowe cylindrycznych regulatorów hydrodynamicznych, Ochrona Środowiska 30(2) (2008) 35-41.
- [16] P. Wójtowicz, A. Kotowski, Badania modelowe stożkowych regulatorów hydrodynamicznych, Ochrona Środowiska 30(3) (2008) 37-44.



Już można zamawiać prenumeratę miesięcznika Instal na 2021 rok.

Druk zamówienia na stronie www.informacijainstal.com.pl